



**DeLonghi**

TASCIUGO  
ARIADRY  
*Slim*  
Dehumidifier



## SOME NOTIONS ON HUMIDITY

Air always contains a certain amount of water in the form of vapour. This determines the level of humidity in an atmosphere.

The capacity of the air to hold water vapour increases with temperature.

This is why in our homes, as soon as the temperature decreases, the vapour contained in the air condenses, as is evident on the colder surfaces in the room, such as the windows, walls etc.

The purpose of a dehumidifier is to remove the excess moisture from the air, avoiding the damage caused by condensation.

Experts have established that the optimum environmental conditions for our well being and for the home are obtained between 40% and 60% relative humidity. With very low temperatures, you are recommended to heat the room even minimally.

This considerably increases the dehumidifying power of the appliance.

With heating, the condensation formed by the water vapour on windows and other cold surfaces evaporates into the air to be collected by the dehumidifier. Air leaving the dehumidifier is usually about 1°C warmer than room temperature.

## DESCRIPTION/ACCESSORIES

1. Control panel
2. Water level viewing window
3. Condensate collection tank
4. Lifting handle
5. Air intake grille
6. Silver ion air filter
7. Air outlet grille
8. Condensate drain hose (2 m)
9. Castors

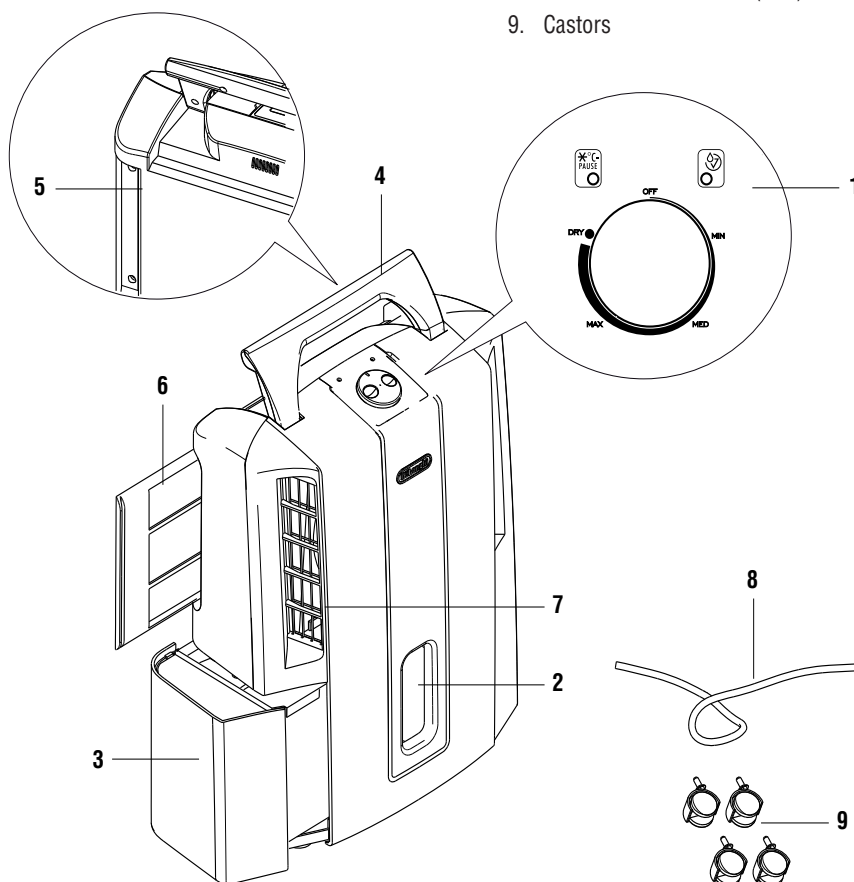

## INTRODUCTION

Thank you for choosing this De'Longhi dehumidifier. To get the best results, please read these instructions carefully before use.

### Symbols used in these instructions

These symbols draw your attention to important warnings.

It is vital to respect these warnings.

Failure to do so may result in electric shock, serious injury, burns, fire or damage to the appliance.



#### **Danger!**

Failure to observe the warning may result in life threatening injury by electric shock.



#### **Important!**

Failure to observe the warning may result in injury or damage to the appliance.



#### **Please Note**

This symbol draws your attention to important recommendations and information.

### Problems and repairs

In the event of problems, first try and resolve them by reading the information given in the "Troubleshooting" section on page 10.

If the appliance requires repair, always contact a Service Centre authorised by the manufacturer.

Always insist on original spare parts. Repairs carried out by unauthorised personnel may be dangerous and can invalidate the guarantee.

## SAFETY

### Fundamental safety warnings



**Danger!** This is an electrical appliance, it is therefore important to respect the following safety warnings:

- Do not touch the appliance with wet hands. This may cause damage.
- Do not touch the plug with wet hands.
- Make sure the mains socket used is always accessible, enabling you to unplug the appliance when necessary.
- Always unplug the appliance using the plug itself. Never pull the cable as this may cause damage.
- To disconnect the appliance completely from the electricity supply, you must unplug it from the mains socket.
- If the appliance malfunctions, do not attempt to repair it. Turn the appliance off, unplug from the mains socket and contact a Service Centre.
- Do not move the appliance by pulling the power cable.
- It is dangerous to modify or alter the characteristics of the appliance in any way.
- If the power cable is damaged, it must be replaced by the manufacturer or an authorised technical service centre in order to avoid all risk.
- Do not use extension leads.
- The appliance must be installed in accordance with the rules on household appliances in force in the country concerned.
- The appliance must be connected to an efficient earth installation. Have your electrical circuit checked by a qualified electrician.



**Danger!** Keep packaging materials (plastic bags, polystyrene foam) out of reach of children.



**Danger!** The appliance is not intended for use by persons (including children) with reduced physical, sensory or mental capabilities, or lack of experience and knowledge, unless they have been given supervision or instruction concerning use of the appliance by a person responsible for their safety. Always supervise children. Make sure they do not play with the appliance.

## Appropriate use

The appliance is designed and produced for domestic use only.

Use this appliance only as described in this instruction manual.

As with all electrical equipment, whilst the instructions aim to cover as many eventualities as possible.

Caution and common sense should be applied when operating and installing this appliance.

## General safeguards

- Do not install the appliance in rooms containing gas, oil or sulphur. Do not install near sources of heat.
- Do not use the appliance on sloping surfaces.
- Keep the appliance at least 50 cm away from flammable substances (alcohol etc) or pressurised containers (e.g. aerosol cans).
- Do not rest heavy or hot objects on top of the appliance.
- Always transport the appliance upright or resting on one side.  
Remember to drain the condensate tank before moving the appliance.  
Wait at least 1 hour after transporting the appliance before starting it
- R134a refrigerant complies with European environmental standards. However, you should avoid perforating the refrigerant circuit.  
At the end of its working life, consign the appliance to a specialist collection centre.  
**ENVIRONMENTAL INFORMATION:**  
This unit contains fluorinated greenhouse gases covered by the Kyoto Protocol.  
Maintenance and disposal must be carried out by qualified personnel only (R134a, GWP=1300).
- The materials used for packaging can be recycled.  
You are therefore recommended to dispose of them in special differentiated waste collection containers.
- Do not use the appliance outdoors.
- Do not obstruct the air intake or outlet.
- Do not use the appliance in laundry rooms.

## Instructions

Read these instructions carefully before installing and/or using the appliance.

- Keep these instructions carefully.  
If the appliance is transferred to other owners, they should also be given these instructions.
- Failure to respect the instructions may result in injury or damage to the appliance.  
The manufacturer is not liable for damage deriving from failure to follow these instructions.
- Keep the list of Service Centres and identify the Centre nearest you.

## Electrical connections

After moving the appliance, wait at least an hour before turning it on again.

Before plugging the appliance into the mains socket, check that:

- The mains power supply corresponds to the working voltage indicated on the rating plate.
- The power socket and electrical circuit are adequate for the appliance.
- The power socket matches the plug. If this is not the case, have the plug replaced by a qualified electrician;
- The mains socket is adequately earthed.



**Important information for correct disposal of the product in accordance with EC Directive 2002/96/EC.**

At the end of its working life, the product must not be disposed of as urban waste.

It must be taken to a special local authority differentiated waste collection centre or to a dealer providing this service.

Disposing of a household appliance separately avoids possible negative consequences for the environment and health deriving from inappropriate disposal and enables the constituent materials to be recovered to obtain significant savings in energy and resources. As a reminder of the need to dispose of household appliances separately, the product is marked with a crossed-out wheeled dustbin.

## INSTALLATION

Position the appliance in the room to be dehumidified. A free space of at least 50 cm must be left at the front of the dehumidifier, so as not to block the air outlet.

For efficient ventilation a space of about 5-10 cm should be left at the back of the appliance.

The condensate can be drained in one of the following ways:

### A) Draining into the tank

The condensate can be drained directly into the tank. The tank can be easily removed (fig.1).

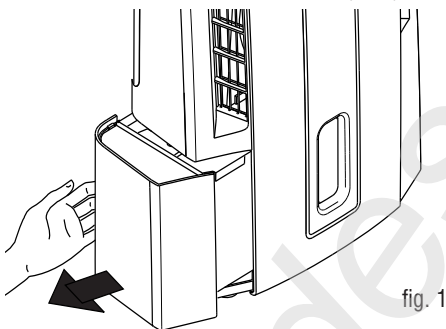

fig. 1

### B) Continuous external draining

If the appliance is to be operated for long periods but you are unable to empty the tank regularly, you are recommended to use the continuous drain facility.

- 1) Remove the continuous drain cap by turning it anticlockwise then remove the rubber bung from the spout (fig. 2).
- 2) Fasten the rubber hose to the spout.

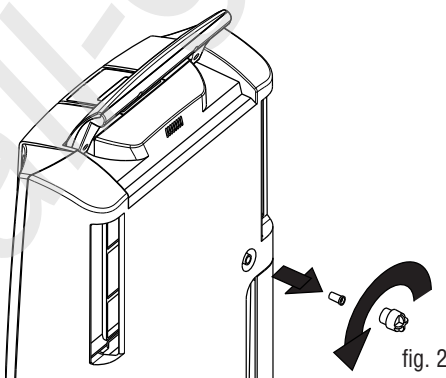

fig. 2

- 3) Make sure the end of the hose is no higher than the spout or water could remain in the tank. Make sure there are no kinks in the hose (fig. 3).

**i** **Please Note:** Keep the rubber bung to close the spout.

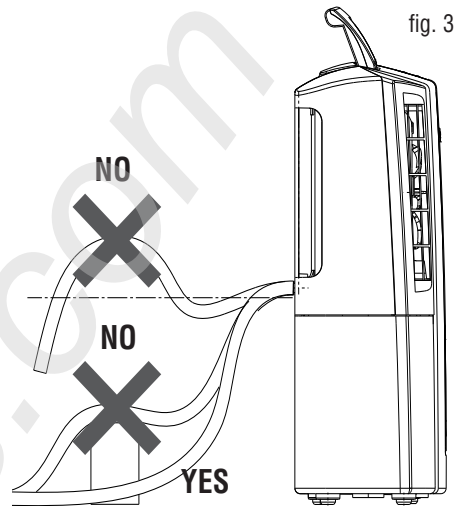

fig. 3

### Instructions for fitting the castors

- 1) Unplug from the mains socket and empty the tank (if full).
- 2) Remove the rubber caps from the bottom of the appliance by pulling forcefully or using pliers (see figure 4/1).
- 3) Fit the castors by inserting the pins into the holes. (see figure 4/2)

**i** **Please Note:** While fitting the castors, do not tilt the appliance at an angle of more than 45°. After fitting the castors, wait for at least an hour before using the dehumidifier again.

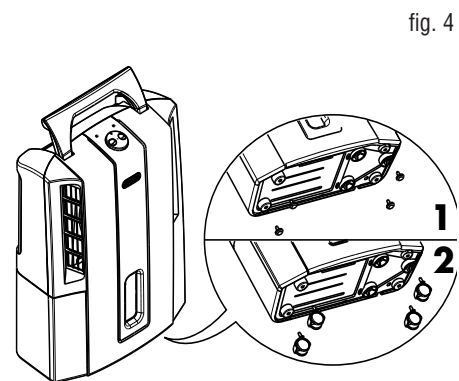
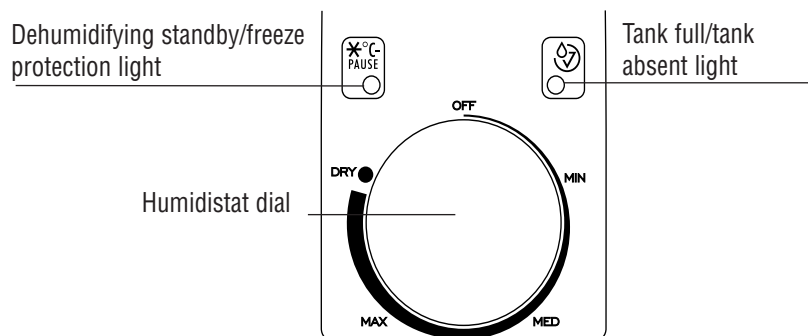

fig. 4

## HOW TO DEHUMIDIFY



### How to dehumidify

- Plug the appliance into a mains socket.
- Make sure the "tank full/tank missing" light is off. If it is on, position the tank correctly.
- The dehumidifying standby light comes on during the first three minutes (safety device), then the appliance starts dehumidifying.
- The humidistat dial is used to adjust the humidity level as desired (MIN/MED/MAX and intermediate levels).

When the dial is on MIN, the dehumidifier removes only a small amount of humidity from the room. On MAX, it removes a large amount of humidity.

To dehumidify, adjust the humidistat to one of the positions available.

### Dry mode (drying washing)

To remove a large amount of moisture (for example when drying washing), you are recommended to operate the appliance at maximum power by turning the humidistat dial to DRY.

In this mode, the dehumidifier operates continuously, irrespective of the level of humidity in the room.

## INDICATOR LIGHTS

---

### Tank control system light

This dehumidifier has a special device to control correct operation.

A red indicator light on the control panel comes on to warn the user when:

1. the tank is full: *empty the tank*
2. the tank is missing: *reposition the tank*
3. the tank is incorrectly positioned: *position the tank correctly*
4. with continuous drain:  
the hose is blocked or sloping upwards (water is still draining into the tank)  
*remove the obstruction*

When the cause has been removed, the light goes off and the appliance resumes operation.

### Dehumidifying standby/low-temperature operation light

The light comes on:

- 1) To indicate the appliance is in standby for about three minutes before start-up. This device protects the compressor from starting and stopping too often.
- 2) To indicate low temperature operation. When the temperature in the room is too low, the low temperature operation electronic device trips. This operates the appliance with alternate cycles of dehumidifying and fan only to avoid the formation of ice.

For frequent use in particularly cold rooms, you are recommended to raise room temperature, even if only slightly.

This ensures that the dehumidifier is operating under suitable conditions, improving its performance and accelerating dehumidification.



## CLEANING AND MAINTENANCE

Always unplug the appliance from the power socket before performing any cleaning or maintenance operations.

For safety reasons, never wash the dehumidifier using a jet of water.

### Cleaning the cabinet

- Clean the appliance using a damp cloth then dry with a dry cloth.
- Do not use petrol, alcohol or solvents to clean the appliance.
- Do not spray liquid insecticide or similar products as they may deform the plastic.

### Cleaning the silver ion air filter

If the filter is dirty, air circulation is compromised and the efficiency of the dehumidifying and air purifying functions decreases.

It is therefore good practice to clean the filter at regular intervals. The frequency depends on the duration and conditions of operation.

If the unit is used constantly or systematically, you are recommended to clean the filter once a week.

- Remove the air filter by pulling sideways (Fig. 5).

fig. 5

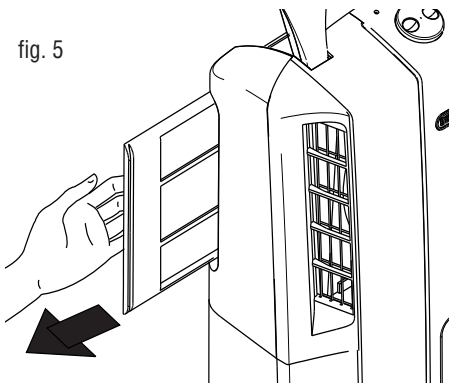

- Use a vacuum cleaner to remove dust accumulations from the filter.  
If the filter is very dirty, rinse well in warm water.  
The temperature of the water must not exceed 40°C.  
After washing the filter, allow it to dry completely before repositioning it.  
The silver ion filter not just retains dust

particles, but also has an efficient antibacterial action. It also greatly reduces concentrations of irritants such as pollen and spores.

The filter is treated with small particles of silver (on the scale of millionths of a millimetre) which are able to block the multiplication of and destroy any bacteria or spores coming into contact with them.

### If the appliance is not used for long periods

- After unplugging the appliance from the power socket, empty the tank.
- Clean and reposition the filter.
- Cover the appliance with a plastic bag to protect it from dust.

## TECHNICAL SPECIFICATIONS

Power supply voltage	See rating plate
Absorbed power	“
Maximum power input	“
Freeze protection device	Yes
Hygrometer	Yes
Fan speeds	1
Air filter	Yes
Dimensions HxLxD	485x375x190
Tank capacity	3 litres

### Operating limits:

Temperature	2°C - 32°C
Relative humidity	30 - 90%

## TROUBLESHOOTING

Check the following points before calling your local authorised Service Centre.

PROBLEMS	CAUSE	SOLUTION
The appliance is operating in dehumidifying mode, but the humidity does not decrease.	The filter is blocked.	Clean the filter.
	The temperature or humidity in the room is too low.	In certain conditions, it is normal for the appliance not to dehumidify (in certain cases, it is recommended to heat the environment).
	The room is too big for the dehumidifying power of the appliance.	
	Too many sources of humidity in the room (pots of boiling water, etc.).	
	The humidity set point is too high.	Decrease the humidity set point.
The appliance does not work for 3 minutes after start-up.	The safety device has tripped.	Wait for 3 minutes to pass.
The appliance does not work.	• The appliance is not plugged in	• Plug into the mains
	• There is no current	• Check the power supply
	• The humidistat is on MIN	• Turn the humidistat to the max position
	• The tank is full of water (red light on)	• Empty the tank
	• The tank is not in the correct position (red light on)	• Gently place the tank in the correct position
	• The tank is missing (red light on)	• Reposition tank
	• Continuous drain: The hose is blocked or sloping upwards (water is still draining into the tank).	• Remove the obstruction