

DEHUMIDIFIER USING DRYFAN® TECHNOLOGY

INTERNATIONAL PATENT PENDING

DEHUMIDIFIER
USER MANUAL

WHITE

DryFan® 8 (white)
DryFan® 12 (white)

STAINLESS STEEL

DryFan® 8 PRO (stainless steel)
DryFan® 12 PRO (stainless steel)

ECOR PRO



Powered by
DRYFAN





Your dehumidifier fights against rust, wood rot, bacteria, fungi and prevents damage from moisture.

SAFETY

- For safety reasons, read this information carefully before operating. Persons who are not familiar with this type of product must not use it.



This appliance must be earthed and should only be connected to an earthed 220 – 240 V / 50 Hz mains supply.



The installation must be in accordance with the regulations of the country where the unit is used.



The unit is designated for indoor operation.

The dehumidifier is safe, however, as with other electrical appliance, use it with care.

- This appliance is not intended for use by persons (including children) with reduced physical, sensory or mental capabilities, or lack of experience and knowledge, unless they have been given supervision or instruction concerning the use of the appliance by a person responsible for their safety.
 - Children should be supervised to ensure that they do not play with the appliance.

SAFETY (2)

- Do not clean the dehumidifier by spraying it or immersing it in water.
- Do not insert any object into the opening of the dehumidifier.
- Disconnect from the mains before cleaning the unit or any of its components.
- Never connect to an electrical outlet using an extension cord. If an outlet is not available, one should be installed by a licensed electrician.
- Place the dehumidifier in location appropriate to the appliance IP rating (see technical data).
- Any service other than regular cleaning setting fan mode or filter replacement should be performed by an authorized service representative. Failure to do so could result in a loss of warranty. Your dehumidifier is supplied with an electrical cable (4200 mm) and an earthed plug. Should it be necessary to replace this plug at any time, you must use an earthed electrical plug.



Warning! Never operate this appliance if it has a damaged cord or plug.
If the supply cord is damaged an approved service representative or a similar qualified person must replace it in order to avoid any hazards.

There should be direct access to the electrical plug after connecting the power!



Do not use your dehumidifier under the following conditions:

- if the power cable is damaged
- where the power cable may be easily damaged
- close to heat source
- where small children may be left unattended
- where there is a risk of liquids falling on top the unit
- where it may be damaged by chemicals

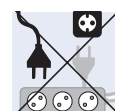

This product is not made for DIY repair.

THANKYOU!

- Thank you for choosing this exciting innovation in drying using DryFan® technology. A unique product and a revolution to the way we keep living spaces, lofts, basements, boats, holiday homes, garages and storage areas dry all day and every day.
This dehumidifier is a tough and can even be used for industrial processes and applications. Designed to be used almost anywhere, in any orientation and will even work upside down. These units will perform similar to compressor dehumidifiers rated at double the capacity at normal room conditions.
Using DryFan® technology these dehumidifiers will out-perform compressor dehumidifiers by 3-4 times below 10 °C. Where compressor dehumidifiers stop working at 5 °C these units using DryFan® technology will continue to dry spaces even continuing to work to -20 °C making them ideal for unheated rooms and out-buildings.



It is important that you read these instructions carefully before installing and using your new dehumidifier. Please keep them in a safe place for future reference.

You can take out your unit easily if you open the box from the top side.

HOW OUR UNIQUE TECHNOLOGY WORKS

- Your dehumidifier uses DryFan® technology and uses a continuously rotating moisture absorbing patented wheel termed a "Rotor".

A highly efficient yet low noise fan draws air into the unit (Process Air) and forces it through a section of the rotor. As the air passes through the rotor, the honeycomb, of hygroscopic membranes absorbs almost all of the moisture creating an extremely dry airstream.

Most of this airstream (approx 85%) is discharged directly through the 'Dry Air Outlet'.

However, a portion, (approx 15%) of this air (Regen Air) is separated and directed through a special heater bank (Regen Heater) where the air's temperature is raised.

This heated air is then channelled back through a section of the Rotor.

As this hot air passes through the membranes, its higher temperature drives-out the previously absorbed moisture and discharges it as warm wet air through the 'Wet Air Out' duct.

As the wheel rotates, this process of collecting and discharging moisture is continuous.

The wet air outlet is 41 mm in diameter making it easy to vent the moisture away using standard push fit waste water connectors.

Water is not drained away as a liquid it is vented away similar to a tumble dryer.

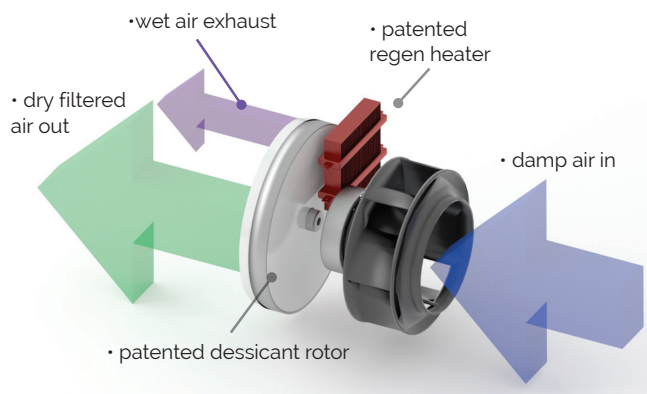

HOW OUR UNIQUE TECHNOLOGY WORKS (2)

- **PATENTED DESICCANT ROTOR**

The Desiccant Rotor is the heart of the DryFan® system. It is an array of especially absorbent membranes – patent protected – arranged as a series of corrugations (as shown in the cut-away image) to give a vast surface area that was developed over many years, making it an extremely efficient moisture collector.

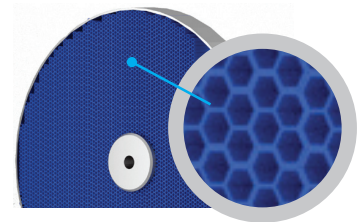

- **PATENTED REGEN HEATER**

A patented ceramic PTC Regen Heater. (PTC Positive Temperature Coefficient) is self regulating so never to overheat. However, as triple safety we include a separate overheat smart sensor in the dehumidifier.

The patented technology is both safe and energy efficient and can never overheat to hazardous temperatures, even if vents become accidentally blocked.

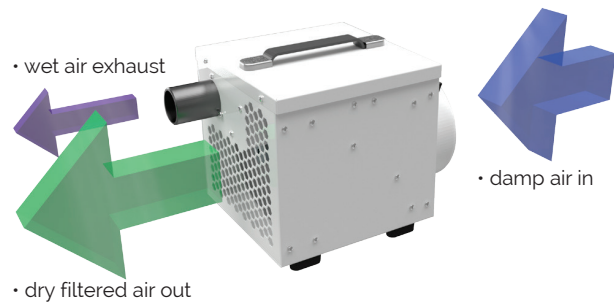
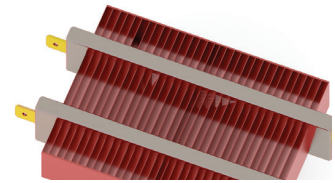

HOW OUR UNIQUE TECHNOLOGY WORKS (3)

FAN SYSTEM

All models use specialised fan technology to give quiet performance but type of fan will differ by model capacity.

Note: External ductwork will reduce restrict airflow and therefore the amount of water the dehumidifiers will extract. To maximise airflow and water extraction always keep any ducting to minimum. Maximum lengths of any ducts are outlined in the table.

Model	Maximum process air in duct length (m)	Maximum wet air out duct length (m)	Maximum process air out duct length (m)
DryFan® 8 & DryFan® 8 PRO	1.0	0.6	No duct flange / not applicable
DryFan® 12 & DryFan® 12 PRO	3.0	1.0	3.0

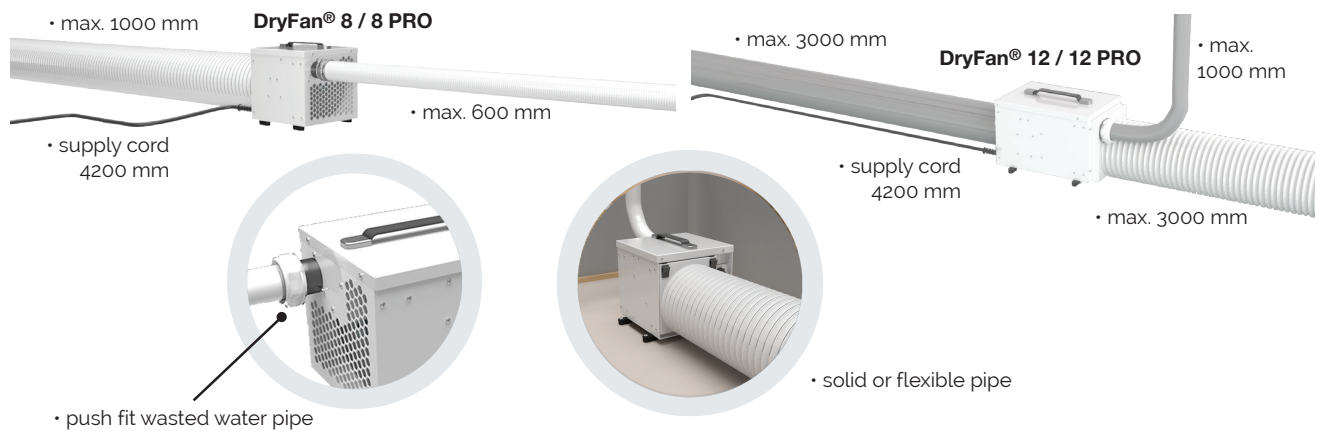

HOW OUR UNIQUE TECHNOLOGY WORKS (4)

● CONTINUOUS FAN OR FAN ON WHEN DRYING ONLY MODES

The DryFan® system can be used in two modes:

Mode 1 – The fan is always blowing and circulating air continuously dehumidifying at the set humidity point by the humidistat. This has the benefit of a faster reaction time to fluctuating humidity levels.

Mode 2 – The fan is working only when needing to dry the air. The reaction time to humidity level change may be up to 1 hour in this mode, but it is more energy efficient and of course quieter working only when needed.

● SELECTING FAN MODE

Modes for the fan can be changed by disconnecting the dehumidifier from the power supply by unplugging. Remove the four screws holding the top cover in place with a screwdriver. On the inside just under the lid is a switch. Pressing the switch will mean mode change from one mode to the other.

Replace the cover the right way round (there is only one way for all screws to align). Put screws back into position taking care not to overtighten.

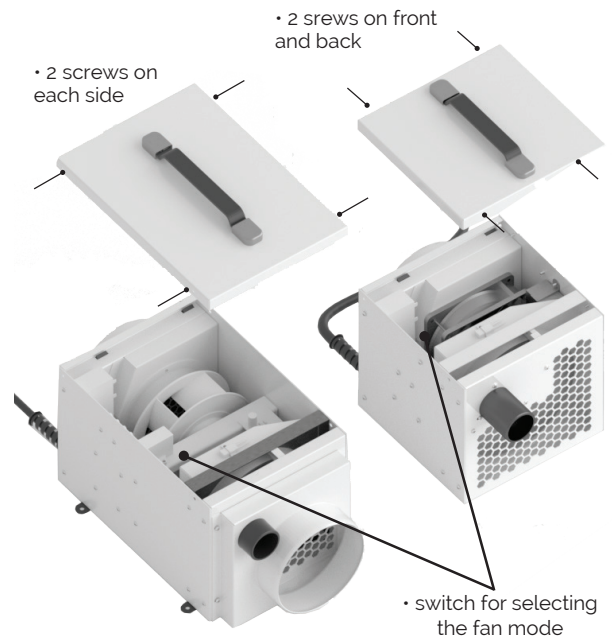

POSITIONING DRYFAN® 8 / 8 PRO

● POSITIONING

The models have been designed for indoor use however, they can be placed inside or outside the room to be dried.

Internal Positioning:

When positioning the unit inside the room, place it centrally, ensuring inlet and outlet ducts are clear of obstruction. If required, ducts can be connected to the outlet and/or inlet (where fitted) to direct the drying to specific areas. The 'Wet Air Out' MUST be ducted outside the room.

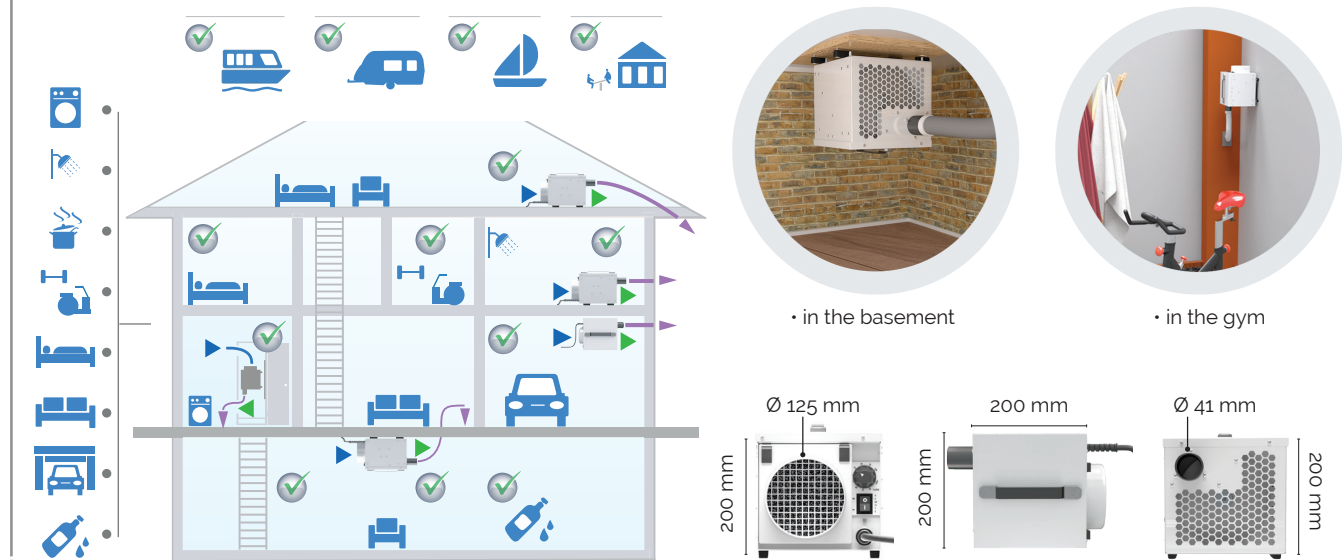

POSITIONING DRYFAN® 12 / 12 PRO

● **External Positioning** (Models where Outlet Duct Fitted Only):

When positioning the unit outside the room, connect ducting to the outlet to direct the dry airstream into the room to be dried. Optionally, the inlet may also be ducted to the room to give a re-circulation effect. In this case however, because the unit uses a portion for the inlet air for regeneration. Provision must be made in the inlet duct to draw air also from outside the room.

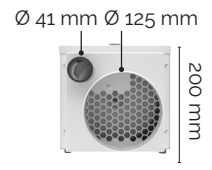
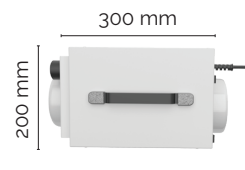
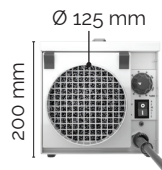
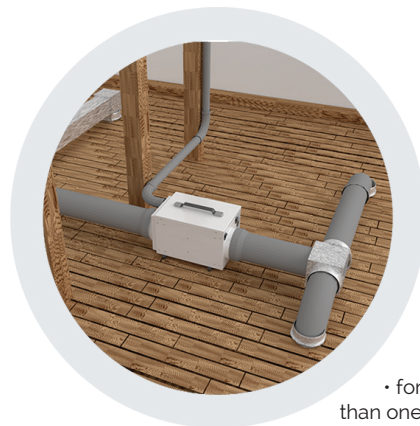
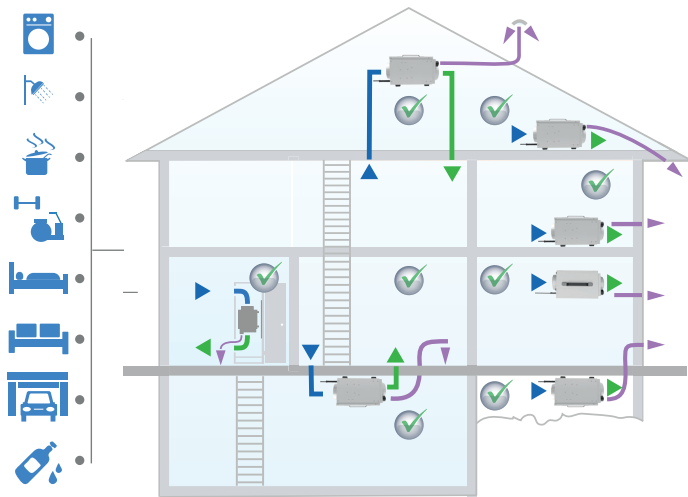

POSITIONING (3)

- **NOTE:** As the Wet-Air-Out discharge is warm and very humid ensure it is directed where it will have no adverse effect on the immediate environment.
- **NOTE:** Wet-air-out should be declined from the dehumidifier where possible if there is a risk of any condensation build up in the exhaust duct running back into the dehumidifier. This can be avoided either with short wet-air-out duct lengths or adequately insulating the wet-air-duct to prevent condensation. Should water be seen dripping from the dehumidifier switch off the appliance immediately at the wall socket. Allow water in the unit to dry completely. Correct the defect in the wet-air-out ducting and reconnect to the power to start operating again. Do not operate if there is a concern the unit is not thoroughly dry inside.

● **NOTE: The wet-air-out flange outlet is 41 mm. This is the standard size of push fit wasted water pipe connectors and pipes ideal for exhaust ducting.** Decreasing the exhaust pipe diameter will decrease performance. Flexible ducting may be used on all inlets and outlets.

All ducting lengths should be kept to a minimum. Longer lengths will reduce performance. For the longest lengths see FAN SYSTEM TABLE (page 7). Ducting may be also supplied by your dehumidifier supplier.



• to the ceiling



• in a closet



• in a laundry room

OPERATION

CONTROLS

The controls are positioned on the front of the unit next to the air outlet duct, they are:

1. Humidistat
2. Remote Humidistat Switch
3. Remote Humidistat Jack Plug Socket

Auto reset. If there is a power out the dehumidifier will automatically restart when the mains power is reconnected.

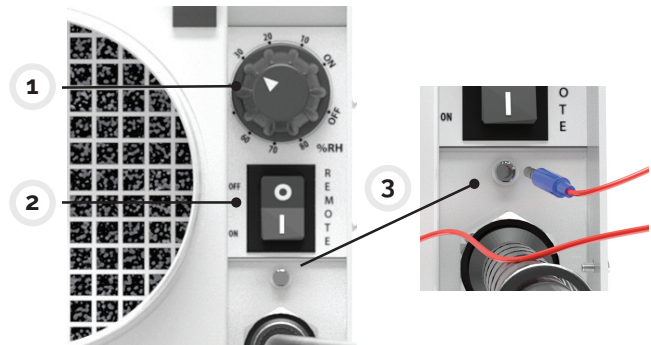

MOUNTING

The dehumidifier can be mounted in any direction even up-side-down.

Turn the feet out to see the anchoring points. Secure all four feet with suitable fixings (not provided) to floor, wall or ceiling.



STAND-ALONE OPERATION

Connect the unit to suitable mains supply and connect ducting.

Ensure the 'Remote Humidistat' switch is set to the 'OFF' position (O). Turn humidistat to lowest humidity level continuation or set the switch to the 'ON' position (I). The fan will start. Set the humidity level right for the room to be dried.

- + Follow the steps in SETTING FAN MODE to alter the fan mode as needed (see page 8).

OPERATION (2)

- **NOTE:** A low setting of say 10% means the room is regulated to a very dry level while a setting of say 90% the room will be maintained at a relatively humid level. The right level for the room may vary with weather, temperature and occupation conditions over time.

- **REMOTE OPERATION**

For remote operation it is necessary to connect an 24V external humidistat (not provided) via the jack plug connector. The external humidistat may be obtained from your appliance supplier. Ensure the "Remote Humidistat" switch is set to 'ON' (O). The dehumidifier will now be controlled by the remote humidistat that is using low power and only 24V.

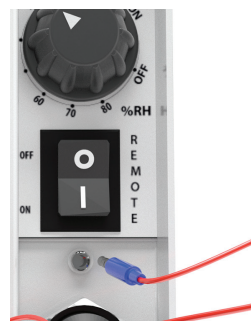

- **CLEANING**

Disconnect from the mains before cleaning or servicing the unit or any of its components. Wipe regularly clean with a moist cloth (a soft, damp cloth) and a mild household detergent. Never use chemicals, petrol, aggressive detergents or other cleansing solutions.

- **AIR FILTER**

The dehumidifier has an inlet air filter. This should be checked periodically and if necessary cleaned. It can be cleaned with a vacuum cleaner or hand washed in mild detergent only.

Replacement filters are available from your supplier.

ATTENTION: Do not run the unit without a filter fitted as dust will impair the performance of the Rotor.

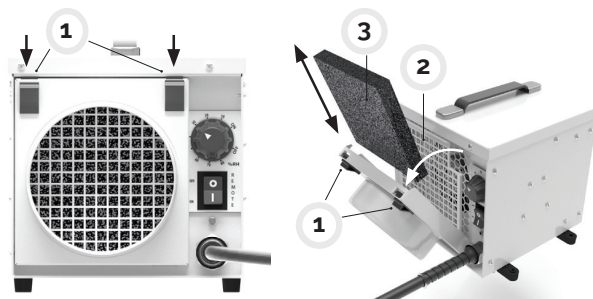

TECHNICAL DATA

Specifications	DryFan® 8 / 8 PRO	DryFan® 12 / 12 PRO
Typical extraction @ 35°C 90%rh	8 l/day	12 l/day
Typical extraction @ 27°C 60%rh	6 l/day	10 l/day
Air flow (Process)	90 m ³ /h	130 m ³ /h
Air flow (Regen)	14 m ³ /h	20 m ³ /h
Mains	230V ~ 1 phase · 50 Hz	230V ~ 1 phase · 50 Hz
Current @ 27°C 60%rh	2.0 A	2.5 A
Power @ 27°C 60%rh	0.45 kW	0.55 kW
UK plug fuse rating	13 A	13 A
Operating temperature range	-20°C — + 40°C	-20°C — + 40°C
Noise level	40 dB	44 dB
IP rating	IP22	IP22
Dimensions l x d x h mm	200 x 200 x 200	200 x 300 x 200
Weight net / gross	4.5 kg / 4.8 kg	5.7 kg / 6.6 kg



Subject to modifications.



Disposal

This marking indicates that this product should not be disposed with other household wastes throughout the EU. To prevent possible harm to the environment or human health from uncontrolled waste disposal, recycle it responsibly to promote the sustainable reuse of material resources. To return your used device, please use the return and collection systems or contact the retailer where the product was purchased.

They can take this product for environmental safe recycling.

GUARANTEE CONDITIONS

- Your dehumidifier is supplied with a 24-month guarantee, commencing on the date of purchase. All material and manufacturing defects will be repaired or replaced free of charge within this period. The following rules apply:
We expressly refute all further damage claims, including claims for collateral damage.
Repairs to or replacement of components within the guarantee period will not result in an extension of the guarantee.
The guarantee is invalidated if any modifications have been made, non genuine parts are fitted or repairs are carried out by third parties.
Components subject to normal wear, such as the filter, are not covered by the guarantee.
The guarantee is valid only when you present the original, dated purchase invoice and if no modifications have been made.

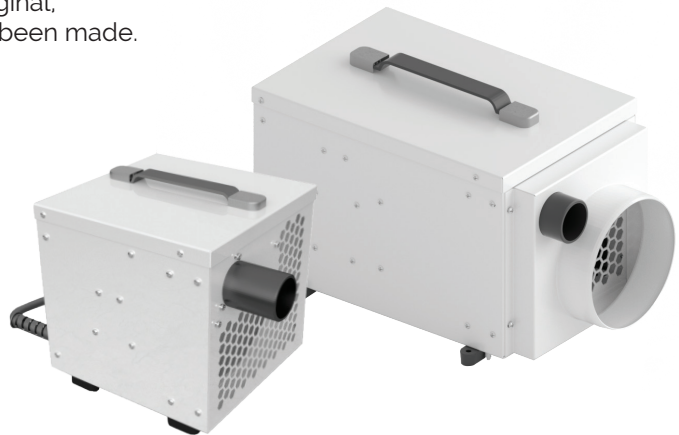

- **Optional parts available from your supplier**
 - Wet air exhaust flexible ducting – 1 meter length
 - Process air In or process air out flexible ducting – 3 meter length
 - Remote humidistat – 5 meter cord length and jack plug
 - Replaceable filters – pack of 3
 - Blank replacement top plate without handle – pack of one



ECOR PRO

Anton Philipsweg 9-11
1422 AL UITHOORN
The Netherlands

Tel.: +31 (0)297 52 75 83
Fax: +31 (0)297 56 01 87

info@ecorproducts.com
www.ecorproducts.com

Chamber of Commerce: 34334850

ECOR PRO

Subject to modifications.