



70-Pint Energy Star Dehumidifier

User Guide

IVALDH70PB

Thank you for purchasing the Ivation® 70-Pint Energy Star Dehumidifier. This User Guide is intended to provide you with guidelines to ensure that operation of this product is safe and does not pose risk to the user. Any use that does not conform to the guidelines described in this User Guide may void the limited warranty.

Please read all directions before using the product and retain this guide for reference. This product is intended for household use only.

This product is covered by a limited one-year warranty. Coverage is subject to limits and exclusions. See warranty for details.

Box contents

70-pint dehumidifier

User guide



Parts

1. Control panel
2. Air intake vent
3. Air filter
4. Water reservoir
5. Handle
6. Air outlet vent
7. Power cord band
8. Drain hose outlet
9. Power cord
10. Power plug

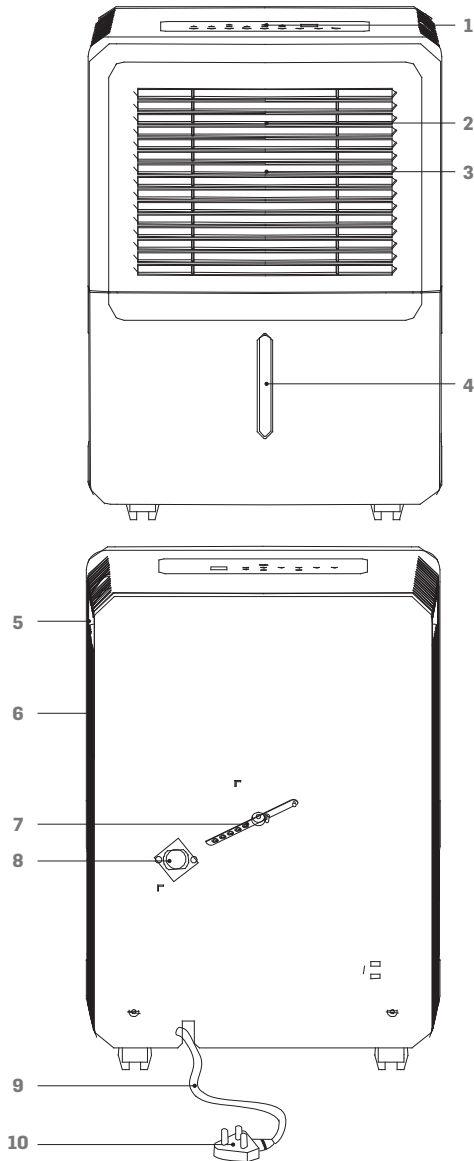

Control panel

- | | |
|------------------------------------|---------------------------|
| 11. Filter light reset button | 18. Clean filter light |
| 12. Continuous (CONT.) mode button | 19. Continuous mode light |
| 13. Timer button | 20. Turbo speed fan light |
| 14. Fan (TURBO) button | 21. Reservoir full light |
| 15. Decrease button | 22. Auto defrost light |
| 16. Increase button | 23. On light |
| 17. Power button | 24. Off light |
| | 25. Digital display |

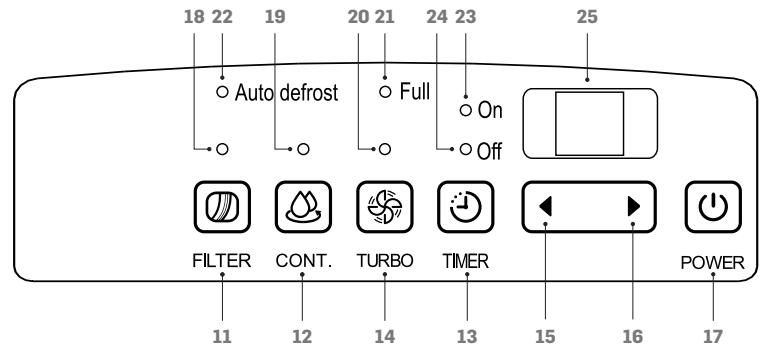

Safety precautions

- Do not exceed the unit's rated power.
- Do not pause the unit by turning off the power.
- Do not use a damaged or unspecified power cord.
- Do not modify the cord length or share the outlet with other appliances.
- Do not handle the plug with wet hands.
- Do not install the unit in a place where it may be exposed to combustible gas.
- Do not place the unit near a heat source.
- Disconnect the power if unusual sounds, smells, or smoke, comes from the unit.
- Never attempt to take apart or repair the unit.
- Before cleaning the unit, always turn off the power and unplug.
- Do not drink or use the water drained from the unit.
- Do not remove the water reservoir during operation.
- Do not place the unit in a place where it may become wet or damp.
- Always place the unit on a level, stable section of the floor.
- Do not cover the intake or exhaust vents with cloths or towels.
- Keep out of reach of children or pets.
- Do not use in areas where chemicals are handled.
- Never insert fingers or other foreign objects into the vents or openings.
- Do not place heavy objects on the power cord.
- Do not climb on or sit on the unit.
- Always insert the filters securely. Clean the filter once every two weeks.
- If water enters the unit, turn it off and disconnect the power. Contact a qualified service technician.

Operation

Before turning the unit on, position it as seen in the diagram. Be sure that you place the unit in a room that is between 41°F (5°C) and 95°F (35°C).

Automatic features

AUTO SHUT OFF: The unit will automatically shut off when either the reservoir is full or the set humidity is reached. Wait 3 minutes before resuming operation.

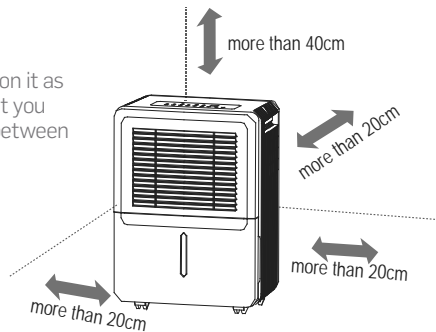

AUTO DEFROST: When frost builds up on the evaporator coils, the compressor will cycle off and the fan will continue to run until the unit has defrosted.

AUTO RESTART: If the power is cut unexpectedly, the unit will restart with the previous settings when power resumes.

Manual features

COMFORT MODE: This mode will set the unit to automatically control humidity between 45%-55% based on the temperature of the room. Note that the humidity cannot be manually set while in this mode.

FILTER: When it is time to clean the filter, the clean filter light will turn on. To reset the light after cleaning the filter, press the filter light reset button.

CONTINUOUS MODE: To set the dehumidifier to run constantly without a timer, press the continuous mode button. The continuous mode light will turn on.

HUMIDITY CONTROL: Relative humidity can be adjusted in 5% increments. For dryer air, press the minus button. For damper air, press the plus button. Note that relative humidity can be set within a range of 35% to 85%.

TIMER: The timer can be set to indicate either when the dehumidifier will start or when it will stop. To set a time, press the timer button until the desired timer light turns on. Use the increase and decrease buttons to adjust the time in .5 hour increments up to 10 hours.

FAN: Press the fan button to switch between high and low fan speed. Note that the higher fan speed will remove more moisture.

Removing collected water

Collected water can be removed in the following ways:

1. When the water reservoir is full, remove and empty it.
2. Continuous draining: water can be automatically emptied into a floor drain by attaching the unit to a water hose with a female threaded end (not included).
 - a. Remove the plastic cover from the drain outlet of the unit and set aside.
 - b. Remove the water reservoir and insert the hose through the drain outlet of the unit, pressing it securely into the connector on the front of the unit.
 - c. Tighten the adapter and the unit with two screws (not included).

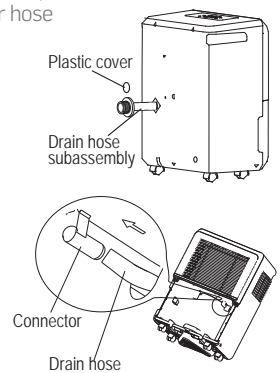

- d. Install the female threaded end of the water hose into the adapter, then lead the water hose to the floor drain or a suitable drainage facility.

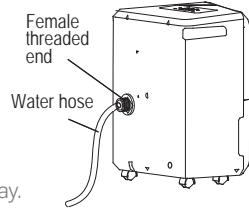

Error codes

The following codes may appear on the LED display.

AS: humidity sensor error

ES: temperature sensor error

P2: the reservoir is full or not positioned correctly

If there is an error, follow the steps below:

1. Turn off the unit
2. Check for any obstructions
3. Restart the unit. If the malfunction is still present, turn off the unit and unplug the power cord.
4. If the error persists, contact the manufacturer, its service agents or a similar qualified person for service.

Care and maintenance

- Always turn the dehumidifier off and unplug before cleaning.
- The water reservoir should be washed with fresh water every few weeks.
- The air filter should be washed with clean water at least every 30 days.
- When storing the unit:
 - After turning off the unit, wait one day before emptying the reservoir
 - Clean the main unit, reservoir, and air filter
 - Wrap the cord and bundle it with a band
 - Cover the unit with a plastic bag
 - Store the unit upright in a dry, well-ventilated place

Specifications

Rated power: 115V

Rated frequency: 60Hz

Rated current: 6.5 amps

Refrigerant: R410A/8.29oz./0.24kg

Moisture removal: 70 pints/day

EEV: 2.0L/kW.H

Design pressure:

High: 540PSIG/3.7MPa

Low: 300PSIG/2.1MPa

Water reservoir capacity: 16gal. (6L)

Troubleshooting

Problem	Solution/Explanation
Unit does not start	Check that the unit is plugged in.
	Check the house's fuse/circuit breaker box.
	The unit has reached its preset level or the reservoir is full.
The unit does not dry the air as it should	Reservoir is not in the correct position.
	Allow the unit more time to remove the moisture.
	Make sure that nothing is blocking the front or back of the unit.
	Select a lower humidity setting.
	Check that all doors, windows, and other openings are securely closed.
The unit is making loud noises	The room temperature is too low (below 41°F; 5°C).
	There is another appliance producing water vapor in the room.
Frost appears on the coils	The air filter is clogged.
	The unit is tilted instead of upright.
	The floor surface is not level.
Water is spilling on the floor	This is normal. The unit has an auto defrost feature.
	The hose connection may be loose.
	The back drain plug is removed.

Customer service:

info@myivation.com

866-849-3049

Distributed by
C&A Marketing, Inc.
114 Tived Lane East
Edison, NJ 08837 USA

Europe: C&A Europe
167 Hermitage Road
Crusader Industrial Estate
London N4 1LZ
United Kingdom

info@myivation.com

Made in China
Ivation and the Ivation logo are registered
trademarks of C&A Holdings, LLC in the U.S.
©2017 All rights reserved