

waykar

Commercial Dehumidifier

Please read the manual carefully
before using the unit

CFD2.5D

USER MANUAL

BEFORE FIRST USE:

To prevent any internal damage, it is very important to keep refrigeration units (like this one) upright throughout their journey. Please leave it standing upright and outside the box for **24 HOURS** before plugging it in.

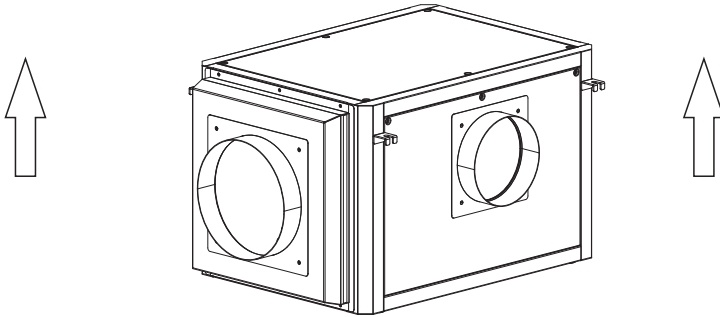

Product description index

Notice Before Use 01

Product Structure 02

Operation Instructions 04

Troubleshooting 07

Safety Cautions 08

Technical Specification 09

Maintenance 10

Warranty 11

FOR CUSTOMERS

Thank you for purchasing our dehumidifier. **waykar** wishes that our products and services can bring convenience to your work and life. We highly recommend that you keep the manual for reference if you encounter unexpected events using the unit. Please read the manual carefully to ensure the proper use of the dehumidifier. Our company's dehumidifier is widely used in family bedrooms, bathrooms, basements, offices, storage rooms, etc. This dehumidifier from **waykar** operates quickly and efficiently to reduce room's humidity and bring you a healthy and comfortable life.

To Access Customer Support Faster

If there is any problem of the product, please contact Waykar Customer Service at support@waykar.com with your purchase Order ID to help us address the problem faster.

Important

For safety purpose, you should read the instructions carefully before using the appliance for the first time.

Save the instructions for future reference.

The appliance is designed for domestic use and may only be installed and operated in accordance with these instructions for use.

1. Unplug the power supply cord before cleaning or storage.
2. Do not immerse the unit in water, or place it close to water.
3. Do not put the unit close to heat-generating devices or near flammable and dangerous materials.
4. Never put your fingers or any stick-form objects into the air inlet or outlet grille.
5. Do not sit or stand on the unit.
6. Discard water collected in the tank as instructed.
7. Install drain piping at a downward direction to make sure that condensed water can be drained continuously.
8. Place and operate the unit on a stable and level floor.
9. Do not spray or splash water directly onto the unit.
10. Do not spray any pesticide nor flammable liquid onto the unit.
11. Do not place any heavy object or let children and pets sit on the unit.
12. Do not operate dehumidifier in a small and confined space.
13. Damaged power cord must be replaced by a licensed technician.

Product Structure

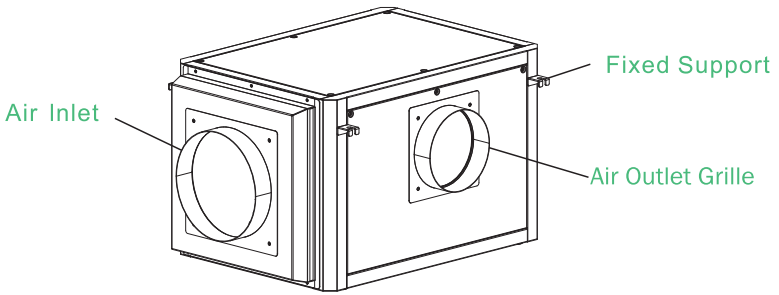

Product Structure

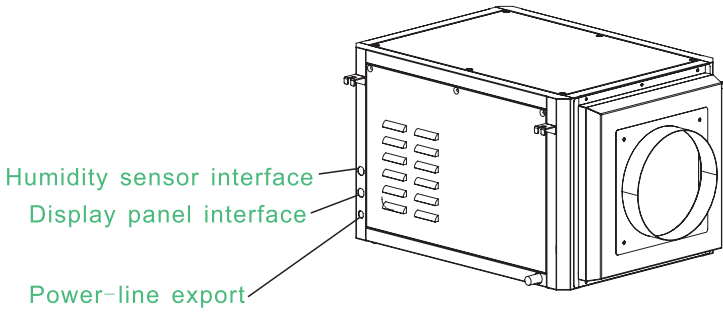

Operation Instructions

Control Panel

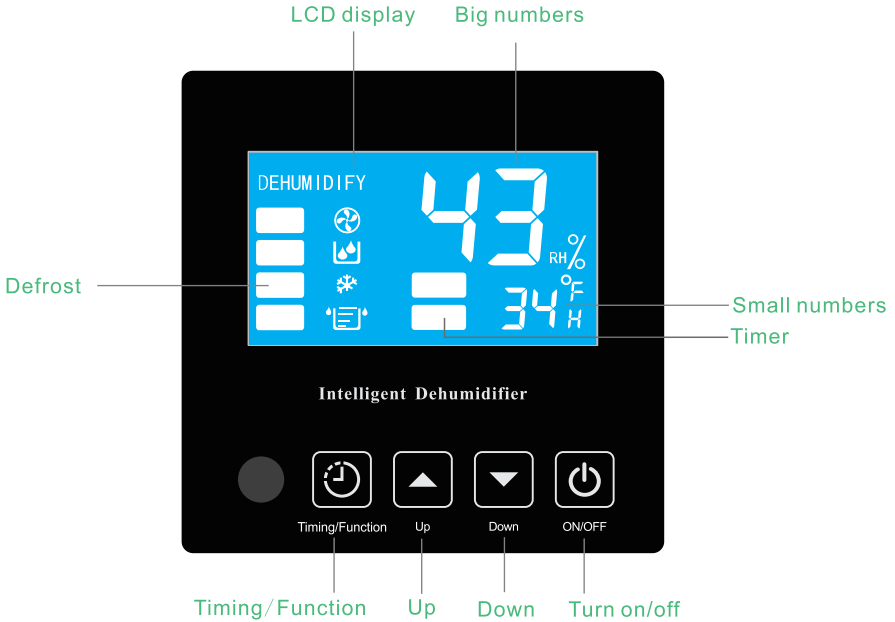

1.Button Description

(1) Power Button

Press the power button, machine will turn on, otherwise off (the LCD screen will light on the power on state, otherwise is off.

Note: When the LCD screen is off does not mean that the power is off.

(2) Up Button

Set humidity value or timer time increments.

(3) Down Button

Set humidity value or timer time decremented.

(4)Timing / function Button

Long time to press will set the timer setting, short press can to confirm parameter settings.

Operation Instructions

2. Humidity Setting

In the power on status, press "up" or "down" button once time to set humidity setting, "% RH" bright, "Humidity" flashes can display humidity setting value "**." . In the humidity setting mode, press "up" or "down" button to set the humidity value, setting range 10-98% RH. Press "Timer / Function" button once or after stop a few seconds to operation it, will automatically exits humidity settings.

3. Timing Shutdown Settings

In shutdown mode, the timing is set to timing for the power on; In the boot state, the timing is set to timing shutdown. In the power on / off state, long press "timer / Function" button for a few seconds to enter the timer setting status: "H" and the timing sign bright, "temperature" flashing display timing time"00." At timing set state, press "up" or "down" key to set the timing, setting range 1 ~ 24h, can to cycling setting. No set timer, "temperature" show the ambient temperature; when the set time is valid, the "temperature" shows the remaining timer time (this time press "Timer / Function" key once, you can view the ambient temperature).

4. Action Description

1. power on: fan start, after a few seconds delay the compressor 1 working, after then a few seconds delay electric heating open, then a few seconds delay compressor 2 start (if it is a single system, the compressor 2 does not start, if it isn't heating function, the electric heating is not open).
2. Power off: compressor 1 and compressor 2 at the same time stop, after a few seconds delay the fan stop.
3. In order to prevent the machine start and stop frequently, there is a delay between starts have 3min.

5. Status Description

In the delay boot state, "run" character flashes; the fan is running, "the fan " bright, otherwise off; when the compressor is running, means in the dehumidification state, "drip icon" bright, otherwise off; when the current humidity reach to request humidity, machine will stop (that's mean in wet control state), "wet control" character flashes.

Operation Instructions

6. Defrost Function

When machine run under low ambient temperature, the system will automatically determine whether there is frost, if have frost, that will automatically defrosted.

Defrost action: the compressor stops.

Defrost ends: Fan continues to run the compressor is turned on.

Defrost display: When defrosting, defrost character or icon flashing, fan icon lights.

7. Temperature Protection Function

When the ambient temperature is higher than the temperature set value (default 113°F), the system enters the high temperature protection, display "HH", the compressor stop.

When the ambient temperature is below the temperature setpoint (default 39.2°F), the system enters low temperature protection, display "LL", the machine stop.

Fault Code

No.	Fault code	Fault name
1	E0	Defrost temperature sensor 2 failure
2	E1	Humidity sensor failure
3	E2	Defrost temperature sensor 1 failure
4	E3	Phase sequence failure (220V power supply is no such failure)
5	E4	Temperature sensor failure
6	E5	High failure
7	E6	Low voltage fault
8	E7	Full water alarm
9	E8	Compressor current overload failure
10	E9	Fan over current fault
11	EA	Defrost temperature sensor 3 failure
12	Eb	Defrost temperature sensor 4 failure
13	Ec	Display information transmission abnormal

Note:

1、if display E0, E1, E2, E4, EA or EB fault, compressors, fans were still working, only alarm and display fault code, turn off the electricity power then turn on still can start (a few seconds for the alarm sound, press any button to reset the alarm sounds).

2、E3, E5, E6, E8, E9 alarms, troubleshooting, need power off, then power on, the alarm will relieve.

3、After try the above solutions, if the malfunction is still present, please don't hesitate to contact Waykar Customer Service Support, email: support@waykar.com for help.

Troubleshooting

When you run into any problems operating this product, use the table below to troubleshoot the problems.

Phenomenon	Cause	Solution
The unit does not operate.	Has the power cord been disconnected?	Plug the power cord into the outlet.
	Is the Tank Full indicator blinking? (The tank is full or in a wrong position.)	Empty the water in the water tank and then reposition the tank.
	Is the room temperature above 95°F or below 41°F	This product is not designed to be used in an environment too cold or too hot. The protection device is activated and the unit cannot be started temporarily.
	Is the room temperature between 41°F and 68°F?	Auto-defrost is in progress. The unit cannot be started temporarily.
The dehumidifying function does not work.	Is the air filter clogged?	Clean the air filter as instructed under "Care & Maintenance".
	Is the air inlet or air outlet obstructed?	Remove the obstruction from the air inlet or outlet.
Operation is noisy.	Is the unit tilted or unsteady?	Move the unit to as table and sturdy location.
	Is the air filter clogged?	Clean the air filter as instructed under "Care & Maintenance".

After try the above solutions, if the malfunction is still present, please don't hesitate to contact Waykar Customer Service Support , email: support@waykar.com for help.

Safety Cautions



Do not place unit on uneven surface.

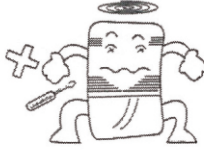

Do not insert any sharp objects into air inlet/airoutlet.

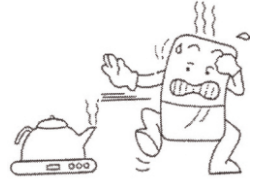

Do not operate unit near radiators, kettles or any object that releases steam.



Do not operate unit near windows or doors opening to the outdoor.



Do not obstruct air inlet and outlet.



Unplug power when the unit is not in use for an extended period.



Do not spray any liquid onto unit.



Do not put heavy objects on top of unit.



Wash the air filter once every 2 weeks with cold water. (Do not use water >40 or benzene)

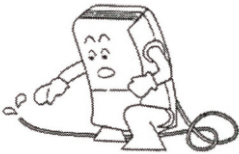

When draining water continuously, make sure drain hose is not tangled.



Do not place filter directly under



Empty water tank before moving unit.

Technical Specifications

MODEL	CFD2.5D
POWER SOURCE	120V ~ 60Hz
RATED POWER(95°F,90%RH)	950W
RATED CURRENT(95°F,90%RH)	8.5A
MOISTURE REMOVAL CAPACITY(65°F,60%RH)	48 Pints/Day(22.7L/Day)
MOISTURE REMOVAL(80 °F,60%RH)	79 Pints/Day(37.3L/Day)
MOISTURE REMOVAL(86 °F,80%RH)	130 Pints/Day(61L/Day)
MOISTURE REMOVAL(95 °F,90%RH)	155 Pints/Day(73.5L/Day)
INPUT POWER(65°F,60%RH)	520W
INPUT CURRENT(65°F,60%RH)	4.7A
IEF(65°F,60%RH)	1.60 liters/kWh
MOTOR FLA	0.9A
MOTOR COMPRESSOR	RLA:6.4A LRA:30A
REFRIGERANT	R410A/16.22ozs(460g)
MAXLMUM ALLOWABLE PRESSURE	800PSIG(5.5MPa)
HIGH PRESSURE	580PSIG(4.0MPa)
LOW PRESSURE	247PSIG(1.7MPa)

Working temperature range from 41°F to 100°F. In the event of the room temperature exceed this range; this part will not work properly.

The parts parameters of above are subject to modification without further notice.

 **WARNING:**

This product can expose you to chemicals including Styrene and its compounds, which is known to the State of California to cause cancer and birth defects or other reproductive harm. For more information go to: www.P65Warnings.ca.gov

Maintenance

In the maintenance and cleaning products before shifting of power line. Clean body using soft damp cloth dehumidifier. Do not use detergent scrub, wire, chemical treatment of the dust cloth, gasoline, benzene, thinner or other soluble. Detergent, because it will damage to the fuselage.

Clean The Filter

This product has a cleanable filter, can remove most of the airborne dirt, such as dust, smoke, animal dander, mold spores and pollen, reduce allergens in the environment.

Recommended periodic check filter, mi-nimum monthly or at Storage before cleaning.

Take Out The Filter Net

1. Vacuum cleaners or gun wind gently remove dirt on the filtering net.
2. If the filter is very dirty, please use warm water and mild detergent washing, and the thorough drying. Don't let direct sunlight or other exothermic products drying filter, which will make the filter net and the deformation of frame.
3. Put the filter back to the product.

Drainage

This dehumidifier only drains by continuously drainage.

1. There is an included drain hose come with the product in the package.
2. When use continuous drainage by drain hose, please make sure the hose is place in smooth way to drain the water, if there is bending or knot, there will be problem of drainage.

Warranty

Waykar offers a 12-month warranty to all of our products, newly purchased and unused, from Waykar or through an authorized reseller, together with the original proof of purchase when a defect occurred, wholly or substantially, or as a result of faulty manufacturing, parts or workmanship during the Warranty Period. The warranty does not apply if damage is caused by other factors, including without limitation of:

- (a) Normal wear and tear;
- (b) Abuse, mishandling, accident or failure to follow operating instructions;
- (c) Exposure to liquid or infiltration of foreign particles;
- (d) Servicing or modification of the product other than by Waykar.

These are our general terms for the warranty service, but we always urge our customers to reach out to us with any issue, regardless of warranty terms. If you experience an issue with a Waykar product, please contact us at support@waykar.com, we will do our best to resolve it for you.

Extend Your Warranty by 1 Year

Register your product at www.waykar.com to extend your 1-year warranty by an additional year.

*Please filled out all required fields and include your order ID, Date of Purchased if applicable.

Customer Support

If you have any questions or concerns about your product, please feel free to contact our expert support team. Waykar customer service is here to help!

Waykar Office

13211, Spring Street Baldwin Park, CA, US

Email: support@waykar.com

Live Chat: www.waykar.com

Support Hours

24 Hours available

*Please have your order number before contacting customer support.

waykar

For FAQs and more information please visit:
www.waykar.com



@Waykar



@Waykar



@Waykar



@Waykar



(Scan the QR Code for Live Chat)

We would love to see our product being used and how it makes your day!! Your support means the world, Please tag us if you share a snap on your social media.

www.waykar.com