

Commercial Dehumidifier

home™
homelabs.com

HME020437N

Thank you for purchasing our quality appliance. Please be sure to read the entirety of this user manual carefully prior to use of the product. If you have any questions regarding the use of this product, please call 1-800-898-3002.

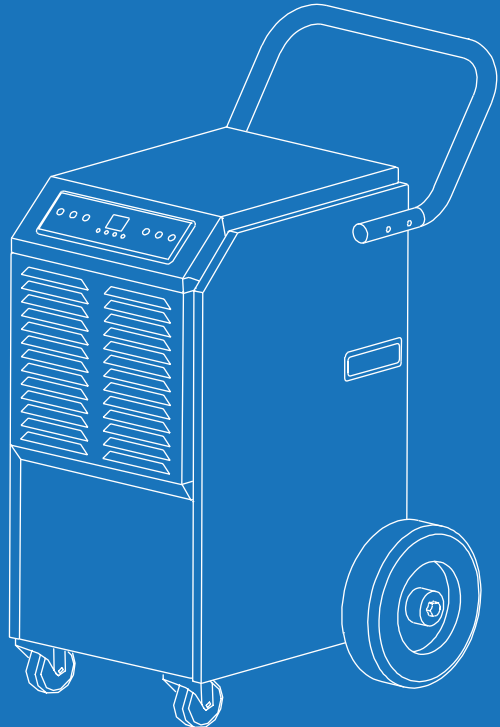

BEFORE FIRST USE:

To prevent any internal damage, it is very important to keep refrigeration units (like this one) upright throughout their journey. Please leave it standing upright and outside the box for **24 HOURS** before plugging it in.

In the event this product malfunctions or customer believes it is defective, the customer should contact Customer Service and retain the defective product pending further instructions. Defective product should be clearly marked or stored where it cannot be used again by mistake. Failure to retain the product may impede hOme™'s ability to correct any legitimate problem and may limit the extent to which hOme™ may provide recourse.

TABLE OF CONTENTS

Important Safety Instructions	6
Installation	7
Operation	8-11
Cleaning and Maintenance	12
Specification	13
Troubleshooting	14
Warranty	15
Manufacturing Info	15
Warning	15
Contact Us	15

Congratulations

on bringing home your new appliance!



Don't forget to register your product at [homelabs.com/reg](https://www.homelabs.com/reg) for updates, coupons, and other relevant information.

Although greatly appreciated, product registration is not required to activate any warranty.

Important Safety Instructions



When using this product, follow below basic precautions to reduce the risk of fire or electric shock. All refrigeration products contain refrigerants, which under federal law must be removed prior to disposal.

- This instruction manual is an integral part of the appliance and should be stored for future reference. It must accompany the unit in event of ownership transfer or for reference by a service engineer.
- Always operate the product from a power source of the same voltage, frequency and rating as indicated on the product identification plate.
- Extreme caution and supervision is necessary when the unit is used near children and pets or when left operating while unattended.
- Do not operate this product with a damaged power cord plug. If the power cord is damaged, do not attempt to repair, it must be replaced with a new power cord supplied by the unit manufacturer in order to avoid a hazard.
- Do not obstruct the inlet or outlet openings. Do not operate in close proximity to walls, curtains, or other objects that may block the inlet and outlet.
- This unit must be plugged into a grounded outlet.
- To reduce the risk of electric shock, do not expose the unit or flexible cord to moisture of any kind.
- Turn off and unplug from the power socket when not in use, before assembling or before cleaning.
- Do not attempt to dismantle the appliance.
- Do not clean the appliance with any chemicals or organic solvent, e.g. Ethyl acetate, gasoline.
- This product is intended for normal commercial use only. Do not use in non-normal commercial settings, whereas the area of use may have a lot of steam or have humidity at, or above 99%. If product is used or installed in a non-normal commercial setting, the warranty will be void.
- This appliance is not intended for locations near to flammable or combustible gas.
- This appliance is not intended to be used by young children without supervision. Young children should be supervised to ensure that they do not play with the appliance.
- Disabled persons and the elderly may require assistance with the set up and usage of this appliance.

SAVE THESE INSTRUCTIONS

Installation

Attach the handle

As the figure shows, attach the handle to the appliance and tighten the screws securely.

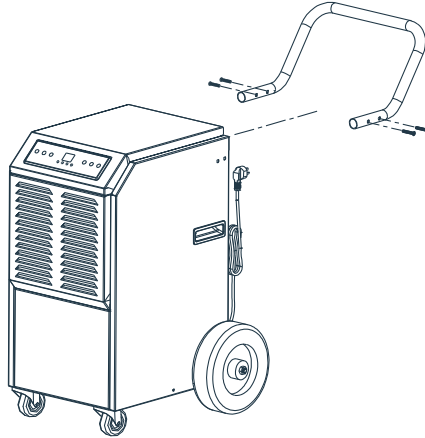

Install the drain hose

Attach the supplied drain hose to the draining nozzle on the appliance. Direct the hose to the desired area before operating the appliance.

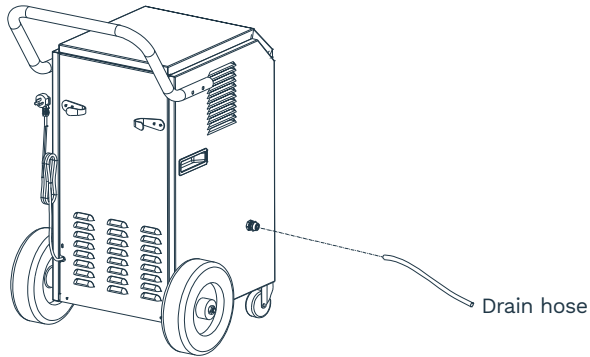

- If the drain area is located above the dehumidifier, the maximum capacity of the water pump is 16.4ft. If the water is drained downwards, there is no limit for the distance.
- Press and hold **DRAIN** button to drain the water manually. The water pump will work for 20 seconds before stopping. Repeat until all water is drained. Drain the water manually before storing or moving the unit.

WARNING:

Do not block the drain hose. The end of the drain hose should not be higher than the outlet hole. If the end of the drain hose is higher than the outlet hole, water will not drain properly and could damage the components of the unit.

Operation

PARTS DESCRIPTION

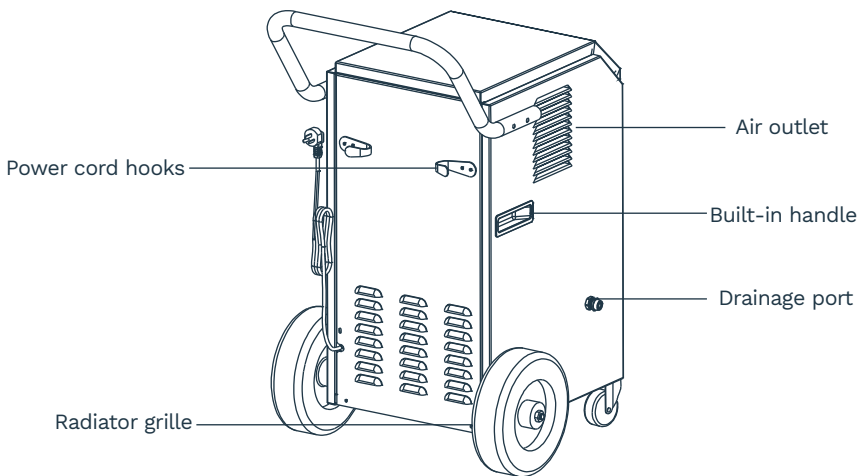
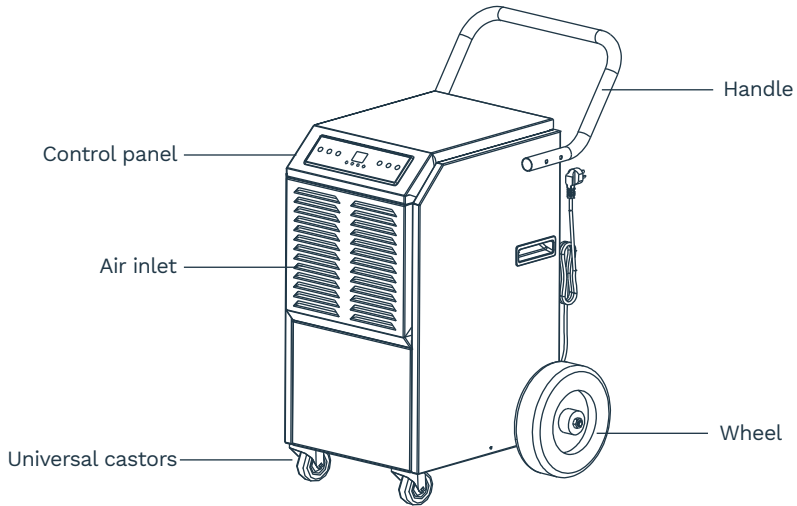

Operation

PLACE THE APPLIANCE

- This unit may have been tilted or placed upside down during shipping. To ensure this device works properly, please ensure this unit is upright for at least 24 hours before initial use.
- This dehumidifier is designed to operate with a working environment between 41°F (5°C) and 90°F (32°C).

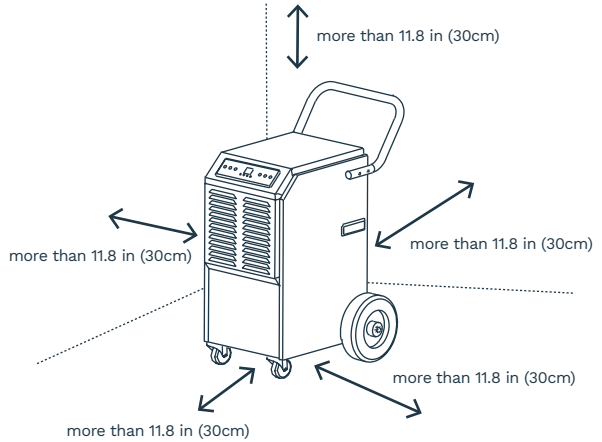

CONTROL PANEL

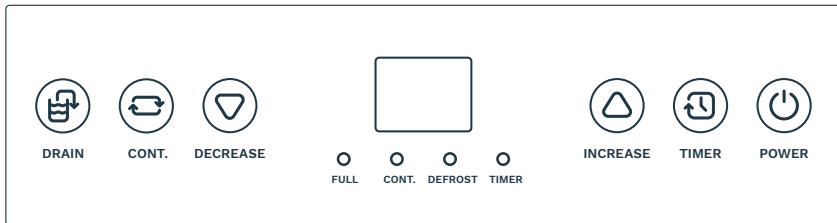

To turn on / off the appliance

- Plug in the appliance, the screen will light up. Press **POWER** button, the unit will start working in continuous mode. The screen displays the environmental humidity. The compressor will start to work 3 seconds after the fan starts working.
- To turn off the appliance, press **POWER** button, the screen displays “- -” and the appliance goes into standby mode. The fan will run for another minute before stopping.

To set the timer

- Press **TIMER** button while the appliance is off, the timer indicator will light up. Press **DECREASE** or **INCREASE** button to set the time to start the appliance. When the countdown is over, the fan and the compressor will turn on.
- Press **TIMER** button while the appliance is running until the timer indicator lights up. Press **DECREASE** or **INCREASE** button to set the time to turn off the appliance. When the countdown is over, the fan and compressor will shut off.
- To display the current temperature, press and hold **TIMER** button for 3 seconds. After 10 seconds, the screen will display current humidity.

Operation

To set the humidity level

The default set humidity level is 50%RH. To increase or decrease the humidity level, press and hold **DECREASE** or **INCREASE** button. The humidity level can be increased or decreased by increments of 5%RH in normal mode.

Note:

Environmental humidity and appliance set humidity will decide the status of the compressor and fan as follow:

- If the environmental humidity \geq appliance set humidity+3%, the compressor and the fan will start running.
- If the environmental humidity $<$ appliance set humidity-3%, the compressor and the fan will stop running.

To use the continuous mode

In continuous mode, humidity setting is invalid. The continuous mode indicator turns on and the screen will display the current humidity. To exit the continuous mode, press **CONT.** button. The humidity setting is resumed.

Water drainage

- When the water pump is full, the water pump will start automatically. The "FULL" indicator will light in red. After 30 seconds, the water pump will stop working and the "FULL" indicator will light off. Press **DRAIN** button to pump the water out even when it's not full. The pump will work for 30 seconds and the "FULL" indicator will turn on and off accordingly.

Operation

- The system has auto memory. If there is a sudden power cut during operation, the system restores the last settings before the power cut and will resume operation upon power resumption.

Defrost Function

1. The appliance will defrost automatically when it is operating at low temperatures. However, the compressor and the fan will shut off if the environmental temperature is below 41 °F or above 100.4 °F.
2. After the compressor ran for 30 minutes, the temperature sensor will detect the copper pipe temperature. When the detected temperature is $\leq 30.2^{\circ}\text{F}$ in the last 10 seconds, the compressor will stop and start to defrost. The fan will keep working and the defrost indicator will turn on. When the pipe temperature reaches 41°F or the defrost lasts for 15 minutes, the appliance quits the defrosting.

Note: During the defrosting, the indicator light will not be off until the defrosting is over.

Operation

Error codes

In case of malfunction, the appliance will display an error code.

E1 - Temperature sensor fails. The system will work in cycles of dehumidification for 30 minutes and defrosting for 15 minutes. The temperature sensor needs to be replaced. Please call customer service for further support.

E2 - Humidity sensor fails. The humidity adjusting button will not work. The system will work in cycles of dehumidification for 30 minutes and defrosting for 15 minutes. The humidity sensor needs to be replaced. Please call customer service for further support.

Protection codes

E4 - The water full switch sensor fails or the water pump fails.

CL - The room temperature is lower than 41°F. The appliance stops running.

CH - The room temperature is higher than 100.4°F. The appliance stops running.

LO - The room humidity is lower than 20%RH. The appliance stops running.

HI - The room humidity is higher than 95%RH. The appliance is working normally.

Note: When one of the above malfunctions occurs, turn off the dehumidifier, and check for any obstructions. Restart the dehumidifier, if the malfunction is still present, turn off the dehumidifier and unplug the power cord. Contact Customer Service for repair and/or replacement.

Cleaning and maintenance

- Clean the appliance with a soft wet cloth.
- Pull the louver on the front panel out to gain access to the filter.

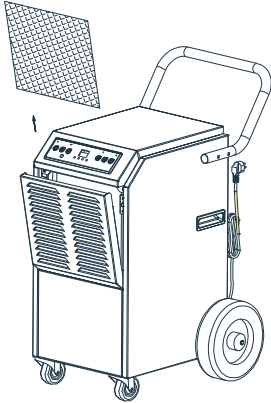

- Remove the filter out of the unit.
- Use a clean rag to adsorb the surface dust on the filter. If the filter is extremely dirty, use tap water to flush it. Fully dry the filter before putting it into the air inlet fence. A clean filter will increase the appliance's efficiency.
- Clean the filter with potable water at least once every 30 days.

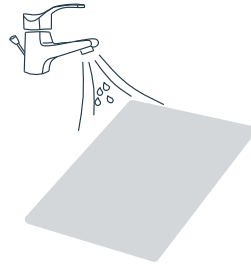

Storage requirements

If not use the unit for an extended period of time, store it per the following steps:

- Clean the filter.
- **ATTENTION!** The evaporator inside the appliance has to be dried out before the unit is packed to avoid component damage. Unplug the unit and place it in a dry open area for days to dry it out.
- Store the power cord on the power cord hooks at the back of unit.
- Cover the dehumidifier with a plastic bag.
- Store the dehumidifier upright in a dry, well-ventilated place.

Specification

Voltage & Frequency	AC 115V 60Hz
Rated Capacity	42Pints/Day @ 65°F, 60% RH
	70Pints/Day @ 80°F, 60% RH
	110Pints/Day @ 86°F, 80% RH
	140Pints/Day @ 95°F, 90% RH
Power Consumption & Current	515W/5.05A @ 65°F, 60% RH
	635W/6.0A @ 80°F, 60% RH
	728W/ 6.75 A @ 86°F, 80% RH
	830W/8.0A @ 95°F, 90% RH
Noise	≤60dB(A)
Air Circulation	265CFM
Refrigerant Type & Capacity	R410A/ 11.6Oz (330g)
Minimum Current of Power Supply	15A
Maximum Design Pressure	High Side: 522psig (3.6MPa)
	Low Side: 240psig (1.65MPa)
Compressor Input	RLA: 6.4A LRA: 38A
Fan Motor Power	0.100HP

Troubleshooting

PROBLEM	CAUSE	SOLUTION
The appliance does not run.	<ul style="list-style-type: none"> The dehumidifier is not plugged well. The house fuse blows or the circuit breaker trips. 	<ul style="list-style-type: none"> Make sure the dehumidifier's plug is inserted completely into the outlet. Replace with a new fuse or reduce power-consuming devices.
	The room temperature is under 41°F or above 100.4°F.	To protect the appliance, use it only when the ambient temperature is between 41°F and 100.4°F.
The appliance runs but does not dehumidify.	<ul style="list-style-type: none"> Did not allow enough time to remove the moisture. The humidity level may not be set low enough. Doors, windows or other openings are open. There is a kerosene heater or something giving off water vapor in the room. 	<ul style="list-style-type: none"> Allow enough time to remove the moisture. Reset the humidity level. Check that all doors, windows and other openings are securely closed. Remove the objects giving off water vapor in the room.
Reduced dehumidifier capacity	The filter mesh is jammed.	Clean the filter mesh.
	The air-in and/or air-out louvers are jammed.	Clear the blockage from the air-in and air-out louvers.
No air inlet	The filter mesh or air-in louver is jammed.	Clean the filter or the louver blockage.
Loud operation	The appliance is placed on an incline or decline slope.	Move the appliance to flat ground.
	The filter mesh is jammed.	Clean the filter mesh.
Water on the floor	<ul style="list-style-type: none"> Hose to connector or hose connection may be loose. Hose is kink. 	<ul style="list-style-type: none"> Reconnect the hose securely. Fix the hose.

Warranty

hOme™ offers a limited one-year warranty (“warranty period”) on all of our products purchased new and unused from hOme Technologies, LLC or an authorized reseller, with an original proof of purchase and where a defect has arisen, wholly or substantially, as a result of faulty manufacture, parts or workmanship during the warranty period. The warranty does not apply where damage is caused by other factors, including without limitation: (a) normal wear and tear; (b) abuse, mishandling, accident, or failure to follow operating instructions; (c) exposure to liquid or infiltration of foreign particles; (d) servicing or modifications of the product other than by hOme™.

The hOme™ warranty covers all costs related to restoring the proven defective product through repair or replacement of any defective part and necessary labor so that it conforms to its original specifications. A replacement product may be provided instead of repairing a defective product. hOme™’s exclusive obligation under this warranty is limited to such repair or replacement.

A receipt indicating the purchase date is required for any claim, so please keep all receipts in a safe place. We recommend that you register your product on our website, homelabs.com/reg. Although greatly appreciated, the product registration is not required to activate any warranty and product registration does not eliminate the need for the original proof of purchase. The warranty becomes void if attempts at repair are made by non-authorized third parties and/or if spare parts, other than those provided by hOme™, are used. You may also arrange for service after the warranty expires at an additional cost.

These are our general terms for warranty service, but we always urge our customers to reach out to us with any issue, regardless of warranty terms. If you have an issue with a hOme™ product, please contact us at 1-800-898-3002, and we will do our best to resolve it for you.

This warranty gives you specific legal rights, and you may have other legal rights which vary from state to state, country to country or province to province. The customer may assert any such rights at their sole discretion.

Manufacturing Info

This manual is to be used with all items with the model number

HME020437N

SKU#: HME020437N

Voltage: AC 115V, 60Hz

Warning

Keep all plastic bags away from children.

Contact Us

 CHAT WITH US

homelabs.com/chat
Mon–Fri 10AM–5PM EST

 CALL US

1-(800)-898-3002
Mon–Fri 10AM–5PM EST

 EMAIL US

help@homelabs.com
Respond within twelve hours



1-800-898-3002
help@homelabs.com
homelabs.com/help

© 2020 hOmeLabs LLC
37 East 18 Street, 7th Floor
New York, NY 10003